



TAC
1354 Clifford Avenue
P. O. Box 2940
Loves Park, IL 61132-2940
www.tac.com

CP-8301-xxx Series

1 to 15 Vdc Input Electronic Actuator Drive General Instructions

Application

The CP-8301-xxx Series electronic actuator drive is designed to process a variable 1 to 15 Vdc signal from a controller to provide proportional control of an electric gear train actuator.

Features

- Mounts directly onto TAC proportional, electric, gear train actuators.
- Fixed 1 to 15 Vdc operating range.
- 24, 120, and 240 Vac models available.
- Color-coded pigtail leads.

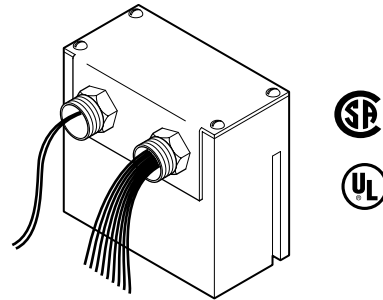

Applicable Literature

- TAC Environmental Controls Cross-Reference Guide, F-23638
- TAC Environmental Controls Reference Manual, F-21683
- TAC Environmental Controls Application Manual, F-21335
- TAC Pneumatic Products Catalog, F-27383
- MP-3xx Series, MP-4xx Series, MP-2xxx Series, and MP-4xxx Series Reversible and Proportional Electric Actuators General Instructions, F-15479

SPECIFICATIONS

Inputs

Control Signal:

Range, 1 to 15 Vdc, nonadjustable.

Span, Refer to Table-1.

Start Point, Refer to Table-1.

Power Requirements: Refer to Table-1.

Power Supplies: Refer to Table-1.

Outputs

Connections: Color-coded pigtail leads.

Mounting: Directly to an actuator. The upright position is preferred, but other positions are acceptable.

Case: Bakelite.

Environment

Ambient Temperature Limits:

Shipping & Storage, -40 to 160° F (-40 to 71° C).

Operating, -40 to 136° F (-40 to 58° C).

Humidity: 5 to 95% relative humidity, non-condensing.

Locations: NEMA Type 1.

Agency Listings

UL 873: Underwriters Laboratories (File #E9429 Category Temperature Indicating and Regulating Equipment).

CSA: Canadian Standards Association (File #LR3728).

Table-1 Specifications.

Part Number	Power Requirement Vac, 4.8 VA 50/60 Hz (+10/-15%)	Power Supply ^b	Start Point of Actuator	Span
CP-8301-024	24	20 Vdc, 50 mA regulated and filtered	Adjustable ^a from 2 to 12 Vdc input Factory-set at 6 Vdc	Fixed at 3 Vdc for full actuator stroke
CP-8301-120	120			
CP-8301-240	240			

^a Remove the TAC logo, then turn the start point potentiometer CW to increase the start point.

^b The power supply must not be connected to the +20 (red) of other supplies.

Table-2 Typical Actuators.

Actuator Series	Power		Torque		Stroke Degrees	Spring Return	Internal Transformer ^a
	Vac 60 Hz	Amp	Lb-in.	N-m			
MP-2113-500	24	2.2	50	5.6	180	—	No
MP-361	24	2.5	50	5.6	180	CW	No
MP-371	24	2.5	50	5.6	180	CCW	No
MP-381	24	2.5	220	24.9	180	—	No
MP-2150-500	120	0.5	50	5.6	180	—	Yes
MP-465	120	0.5	50	5.6	180	CW	Yes
MP-475	120	0.5	50	5.6	180	CCW	Yes
MP-483	120	0.5	220	24.9	90	—	Yes
MP-485	120	0.5	220	24.9	180	—	Yes
MP-486	120	0.5	220	24.9	180	—	Yes
MP-495	120	0.95	450	50.8	180	—	Yes

^a Units with a "-2" suffix, e.g. MP-xxxx-xxx-2-x, include a built-in transformer (used for TAC Microtherm[®] or with AE-504) with secondary leads wired externally to terminals seven and eight of the actuator. Red (24 Vac) to terminal eight and Blue (12 Vac) to terminal seven. When these actuators are used with controllers other than TAC Microtherm or AE-504, disconnect the Red and Blue leads and tape off. Note: Models prior to "-2" suffix had transformer wired directly to potentiometer. To disconnect the transformer, remove the back plate of the actuator, disconnect and tape the transformer leads.

ACCESSORIES

None

TOOLS

Appropriate screwdriver

TOOL-201 Calibration kit for TAC System 8000™

TYPICAL APPLICATIONS (wiring diagrams)

Refer to Figure-1 for a service application wiring diagram showing the connections between a CP-8301-xxx series drive and an MP-3xx, MP-4xx or MP-21xx series actuator.

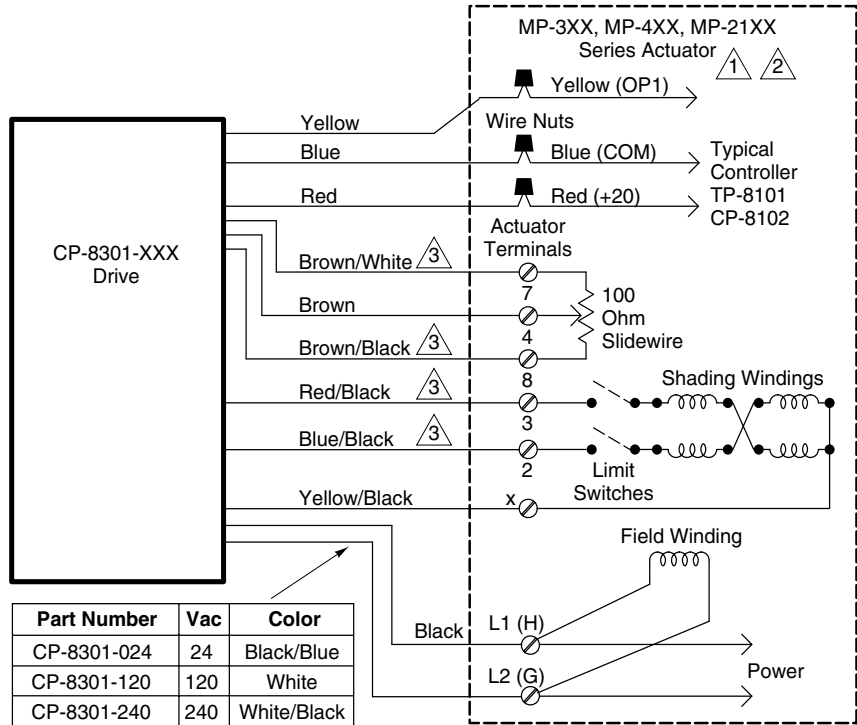

- ① For actuator with internal transformers. Disconnect red and blue leads from actuator terminals 7 and 8 and tape off.
- ② Diagram shown: increasing input causes CW actuator rotation. All references to the direction of rotation are determined by looking at the actuator output shaft.
- ③ For CCW rotation with an increasing input signal, reverse the wires to terminals 7 & 8 and 2 & 3.

Figure-1 Service Application Wiring Diagram.

INSTALLATION

Inspection

Inspect the package for damage. If damaged, notify the appropriate carrier immediately. If undamaged, open the package and inspect the device for obvious damage. Return damaged products.

Requirements

- Tools (not provided):
 - Appropriate screwdriver
 - Digital Volt-ohm Meter (DVM)
- Training: Installer must be a qualified, experienced technician
- Other accessories as appropriate
- Wiring diagrams



Warning:

- Electrical shock hazard! Disconnect power before installation to prevent electrical shock or equipment damage.
 - Make all connections in accordance with the electrical wiring diagram and in accordance with national and local electrical codes. Use copper conductors that are suitable for 75°C.
-

Caution:

- Do not exceed the ratings of the device(s).
 - Static charges produce voltages high enough to damage the electronic components. Follow static electricity precautions when installing or servicing the device(s).
 - Discharge any static electricity you may have accumulated. Discharge static electricity by touching a known, securely grounded object.
 - Avoid locations where excessive oil, dust, moisture, corrosive fumes or vibration, or an explosive atmosphere is present.
-

Mounting

Upright mounting of the drive is preferred, but other positions are acceptable.

Mount the drive onto an actuator as follows:

1. Insert the drive's two 1/2" conduit connectors into the two 1/2" knockouts provided on the actuator casing. Refer to Figure-1, Figure-2, and Figure-5.

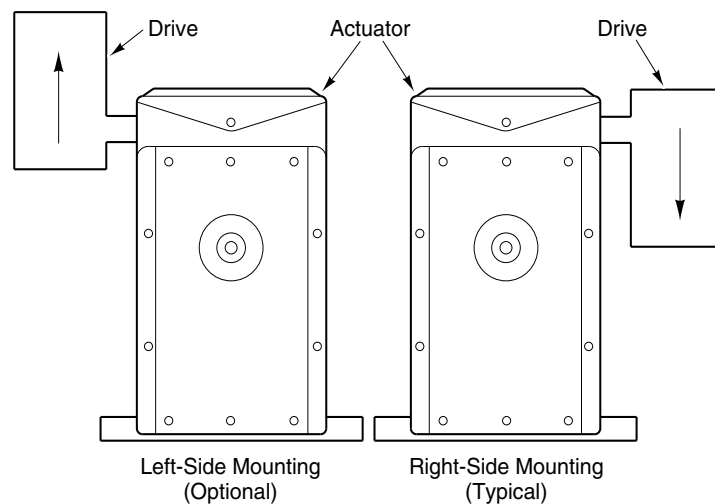

Figure-2 Mounting Position of Drive on Actuator.

Caution: The power wires must always be inserted directly into the power wiring compartment of the actuator. If the optional mounting position for the drive (refer to Figure-2) is used, it is required that the wires of the drive are routed to exit through its other conduit bushing.

2. Secure the drive to the actuator with the two locknuts provided. Refer to Figure-3.

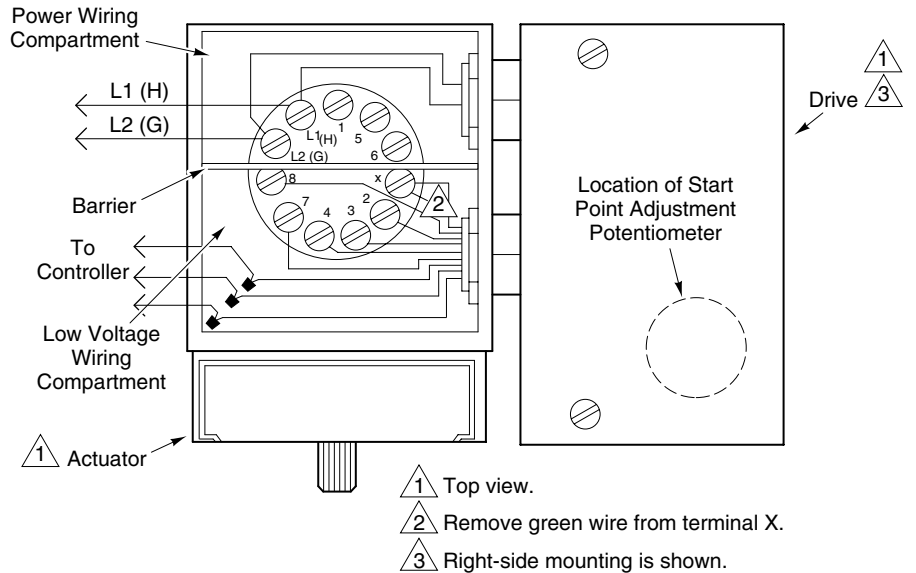

Figure-3 Actuator/Drive Wiring and Mounting Arrangement.

WIRING

Power Wiring

All the power to the drive is supplied by the electric actuator onto which the drive is mounted. Refer to Figure-4. Refer to Table-3 for power wire selection.

Table-3 Power Wire Selection.

Actuator Voltage Vac	Wire Size AWG	Maximum Run (each run has two wires) ft (m)
24	14	140 (43)
	12	125 (76)
120	14	2100 (640)
240		

All the applicable actuators have a barrier that separates the power wiring compartment from the low voltage wiring compartment. The power wiring for the 24 Vac actuators may be per Class 2 circuit requirements if the auxiliary switch (terminals one, five, and six) is 24 Vac, or is not used. The power wiring must be per Class 1 circuit requirements if the actuator is line voltage or if the auxiliary switch is powered by line voltage. The connections to the low voltage wiring compartment may be per Class 2 circuit requirements.

Input Wiring

The drive's two input wires, which must be connected to the controller, are color-coded blue (COM) and yellow (OP1). Refer to Figure-4.

Use 18 gage, three-conductor, twisted leads (part number W-103) for runs of up to 1000 ft. (305 m) between the controller and the actuator. Use larger-sized leads for longer runs.

Caution:

- Use 18 gage, shielded, twisted cable when it is necessary to install the signal leads in the same conduit with the power wiring, or when high RFI/EMI generating devices are near.
- Terminate the shielding on the signal leads at one end only, using the controller's COM (negative) terminal. Grounding the shielding at both ends could create a potential difference in the shielding, which may affect the signal voltage carried by the leads.

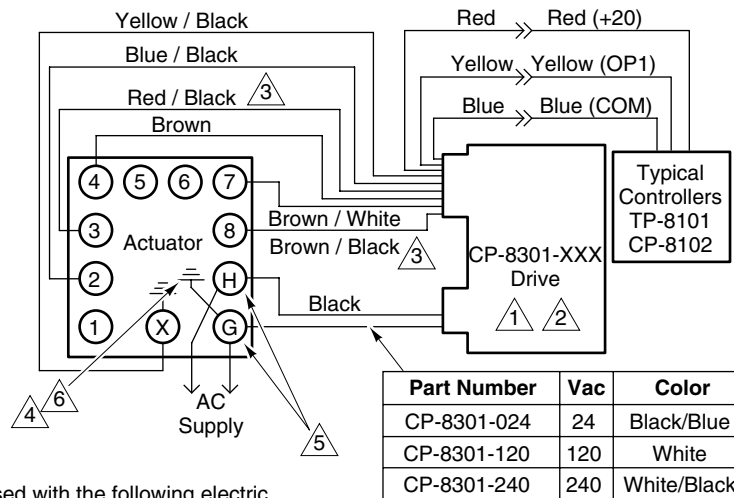

1 CP-8301-024 can be used with the following electric actuators: MP-361, 371, 381, 382, 2113-500 and 9713. CP-8301-120 can be used with the following electric actuators: MP-465, 475, 483, 485, 486, 495, and 2150-500.

2 CP-8301-240 can be used with 240 Vac electric actuators. (Available as a standard option.)

3 Actuator rotates clockwise on increase in input signal. To rotate actuator counterclockwise on an increase in input signal, reverse blue/black and red/black leads and reverse brown/black and brown/white leads.

4 24 Vac Actuators Only.

5 These terminals are marked L1 & L2 on 120V and 240V actuators. 120V and 240V actuators must not have a built-in transformer, or if a built-in transformer is present, remove red and blue leads from terminals 7 and 8, and tape off.

6 External green jumper from X to case ground (and G to case ground, for 24 Vac) on MP-XXXX-XXX-X-2 models only.

Figure-4 Installation Wiring Diagram.

ADJUSTMENTS

Start Point Adjustment

The start point of these actuators is factory-set to 6 Vdc and is field-adjustable from 2 to 12 Vdc. If a start point other than 6 Vdc is required, proceed as follows:

1. Peel back the TAC label from the drive, to expose the start point adjustment potentiometer. Refer to Figure-3.
2. Disconnect the red, yellow, and blue leads of the drive from the controller.
3. Connect the leads of TOOL-202 to the like-colored leads of the drive.
4. Connect a DVM to the yellow (OP1) and blue (COM) leads of the drive.
5. Adjust TOOL-202 until the DVM reading equals the required start point voltage (2 to 12 Vdc).
6. Adjust the actuator start point, using a small, single-slotted screwdriver, so that the actuator shaft just begins to rotate when the desired voltage is applied.
7. Press the label back onto the drive.

CHECKOUT

After the entire system has been installed and the actuator has been powered up, the following checks can be made for proper system operation.

Positioning with Controller

If the sensed media is within the controller's setpoint range, the actuator can be positioned by adjusting the controller setpoint up and down. Check for correct operation of the actuator (valve or damper) while it is being stroked.

Go, No Go Test

1. Disconnect the field wiring from the red, yellow, and blue leads of the drive.
2. Apply power to the actuator.
3. Short the yellow and red leads of the drive. The actuator should rotate CW to its limit, unless it is rewired to rotate CCW on an increase in input signal. Disconnect the short between the yellow and red leads.
4. Short the yellow and blue leads of the drive. The actuator should rotate CCW to its limit, unless it is rewired to rotate CW on an increase in input signal. Disconnect the short between the yellow and blue leads.
5. If the assembled actuator and drive passes steps 3 and 4, they are functioning correctly. If the assembly does not pass these steps, proceed to the next step.
6. Unhook the drive leads from actuator terminals x, 2, and 3.
7. Short actuator terminals x and two. The actuator should rotate CW to its limit. Disconnect the short. The actuator should stop rotation.
8. Short actuator terminals x and three. The actuator should rotate CCW to its limit. Disconnect the short. The actuator should stop rotation.
9. If the actuator passes steps 7 and 8, it is functioning correctly. If the actuator does not pass these steps, the drive may still be functional but the actuator must be replaced.

Manual Positioning

1. Apply power to the actuator.
2. Disconnect the actuator's control leads from the controller.
3. Attach the leads from the manual positioner (TOOL-202) to the like-colored leads on the drive.
4. Manually position the actuator by turning the knob of the manual positioner.
5. Check for proper operation of the valve or damper as the actuator is operated.
6. Remove power from the actuator.
7. Reconnect the actuator wires to the controller.

MAINTENANCE

The drive requires no maintenance.

Regular maintenance of the total system is recommended to assure sustained, optimum performance.

FIELD REPAIR

None. Replace an inoperative drive with a functional unit.

DIMENSIONAL DATA

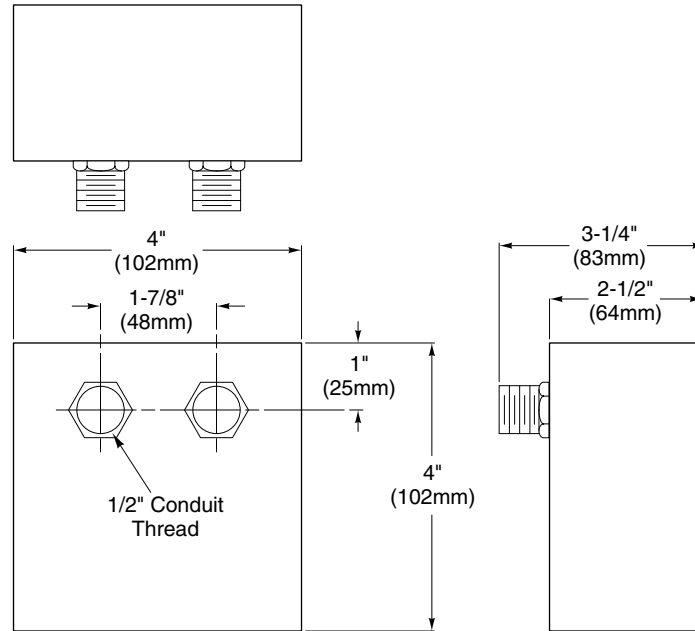

Figure-5 Mounting Dimensions of CP-8301-xxx Series Electronic Actuator Drive.

Copyright 2006, TAC
All brand names, trademarks and registered trademarks are the property of their respective owners. Information contained within this document is subject to change without notice.

TAC
1354 Clifford Avenue
P.O. Box 2940
Loves Park, IL 61132-2940

F-14940-5